

6 Covers

6.4 Covers series CPT in PVC

Plastic covers, made of preformed anti-shock, neutral colour, transparent PVC. Thanks to the characteristics of the material, they are light, transparent, anti-corrosive and with a smooth surface. Above all they are easy to adapt to any conveyor.

Apart from their resistance to corrosion they are classified "NON FLAMMABLE" DIN 4102.

Notwithstanding this property of self-extinguishing, the limit to the use of PVC covers in hot areas should not exceed 65°C.

PVC covers are produced in sections by heat forming sheets into "greek style" corrugations with profile and dimensions available to suit the most common belt widths.



Greek module type ONDEX

Colour : T00 translucent

Thickness: 1.2 mm

Greek module	Sketch of profile	Total length mm	Corrugations n.
70/18		1090	15 and 1/2

Storage and handling

The covers must be stored and handled in flat position on pallet, maintaining the white protection film (as they are dispatched).

Warning: do not expose the packed

covers to direct sun light or to heat sources, when not assembled on the conveyor.

Store them in shady aired place. Not respecting these prescriptions can cause cover's deformation due to heat.

The mechanical properties of the belt covers are summarised in the following table.

Characteristics	Standards	Units	Values for colors Translucent
Mass per unit density	ISO R1183/NFT 51063	Kg/dm ³	1.39
Flexibility elasticity modulus	ISO R178/NFT 51001	MPa	3000
Traction elongation modulus	ISO R527/NFT 51034	%	80/85
Traction impact resistance from -20°C to 23°C	DIN 53488	kJ/m ²	>=300
Vicat point (49N)	ISO R306/NFT 51021	°C	79
Fire rating	NF 92507		M1
Thermal conductivity	DIN 52610	W/ml°C	0.14
Thermal expansion coefficient from -30°C a +30°C	ASTM D696	10 ⁻⁶ mm/mm°C	68.5
Light transmission	ASTM D1494	% compared to air	>=62
Weight according to profiles		kg/m ²	>=1.95
Anti-UV treatment		Grade from 0 to 20 (0 = no protection)	16

6 Covers

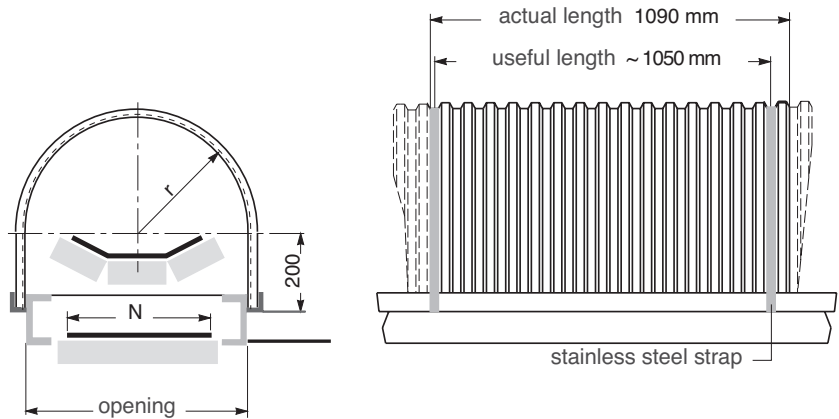

Cover Type	Belt width mm	Opening mm	Radius r mm	Development straights mm	Weight kg	Fixing accessories*	Nr. of accessories per cover
CPT 1	400	700	350	1500	3.6	CPT 1F 400	1
2	500	800	400	1660	4.0		1
3	650	950	475	1890	4.5		1
4	800	1150	575	2200	5.3		2

(*) Fixing accessories

*type CPT 1-2-3

- 1 Stainless steel strap and spring with galvanised hook
- 1 Fixed galvanised hook
- 2 Bolts M8x20 cadmium plated
- 2 Washers cadmium plated

*type CPT 4

- 2 Stainless steel straps and spring with galvanised hook
- 2 Fixed galvanised hooks
- 4 Bolts M8x20 cadmium plated
- 4 Washers cadmium plated

Installation method

Each cover section must be fixed by a stainless steel strap of 20 mm width and 0,6 mm thickness.

The steel strap is positioned on top of the section in the lower corrugation. During the installation the stainless steel straps must be cut and punched.

The last section of each conveyor needs one supplementary set of accessories.

Example of ordering:

CPT 3, 650 quantity 5
plus fixing accessories
CPT 1F, 400 quantity 5+1=6

CPT 4, 800 quantity 3
plus fixing accessories
CPT 1F, 400 quantity 6+1=7

The steel strap is positioned and fixed as follows:

- a) on one side in the angle section drilled to accept bolts and washers M8x20.
- b) on the other side and in the identical position with a zinc plated hook fixed to the angle section with a bolt, nut and washer M8x20.

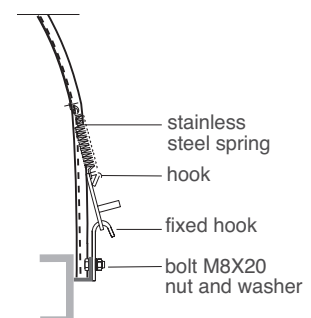
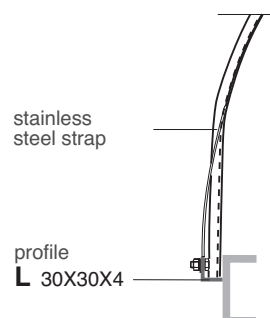

6 Covers

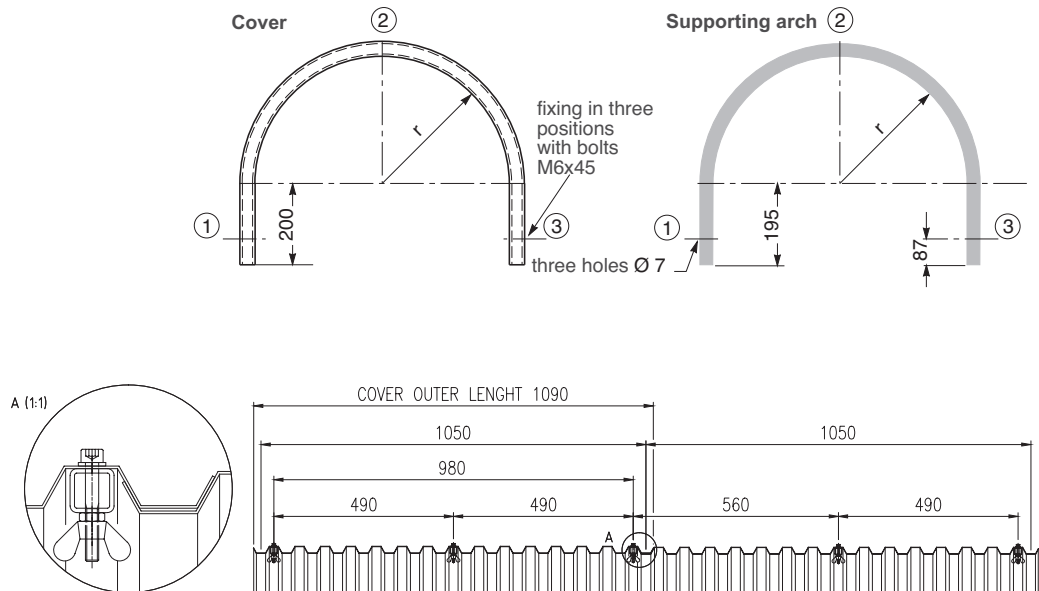

*type CPT 5-6-7

- 2 Arch in profile 20x20x2 galvanized
- 6 Screws M6x45 zinc-plated
- 6 Nuts M6 zinc-plated
- 6 Washers zinc-plated
- 6 Locking nuts M6 zinc-plated
- 2 Fixing brackets 30X4X120 in zinc plated steel

Cover Type	Belt width mm	Opening mm	Radius r mm	Development straights mm	Weight kg	Nr. of accessories per cover	Fixing accessories with supporting arch*
CPT 5	1000	1350	675	2520	6.0	2	CPT 5F 1000
6	1200	1600	800	2910	7.0	2	6F 1200
7	1400	1800	900	3230	7.7	2	7F 1400

(*) fixing accessories

The last section of each conveyor needs one supplementary set of accessories.

Example of ordering

- CPT 5, 1000 quantity 3
- plus fixing accessories
- CPT 5F, 1000 quantity 6+1=7

Installation method

For these covers it is necessary to position two supporting arches made from galvanised steel tube, one at the overlap junction and the other at the centre of each section. The arches must be fixed as indicated in the top figure.

The pre-formed PVC cover and the steel arch are both positioned in the angle profile with brackets and fixed and locked by bolts (M6X45), washers and wing nuts in the 3 points 1, 2 and 3.

