



3 Troughing sets

transom self-centrising model S

Q1 L

Q1 P

return model with fixed lever-arm for single directional belts.

Guide rollers type PSV/G7-NCD 20M16 60N 100 have to be ordered separately.

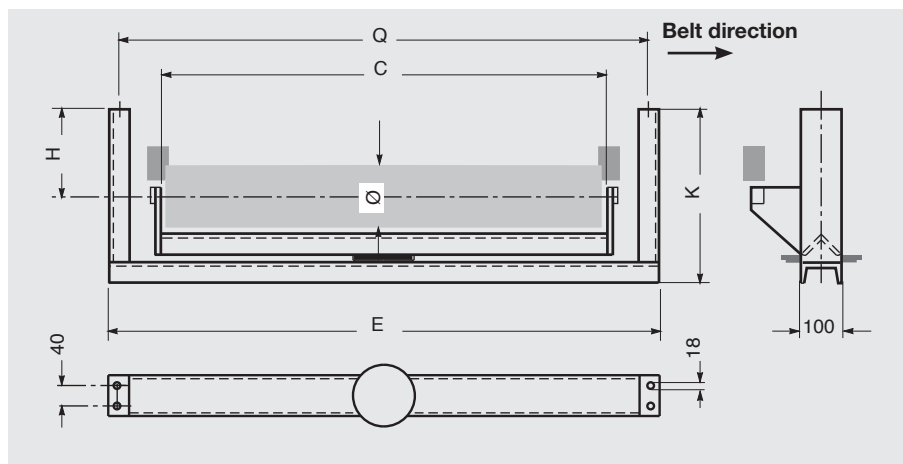

Q1 L

for rollers series:

MPS
 ø 76, 89, 102
 spindle 15
 bearing 6202
 ch = 17

PSV/1-FHD
 ø 89, 108, 133
 spindle 20
 bearing 6204
 ch = 14

belt width mm	roller		ch	self-centrising transom					weight without rollers Kg
	ø mm	C		capacity Kg	H mm	K _{max}	Q	E	
400	76-89-102 108-133	508	14 - 17	175	70	259	640	700	20.8
500		608		143	70	259	740	800	22.2
650		758		197	70	267	890	950	25.9
800		958		158	70	267	1090	1150	29.1
1000		1158		209	70	275	1290	1350	34.7
1200		1408		167	70	275	1540	1600	39.2

Q1 P

for rollers series:

PSV/2-FHD
 ø 133
 spindle 25
 bearing 6205
 ch = 18

PSV/4-FHD
 ø 159
 spindle 30
 bearing 6206
 ch = 22

belt width mm	roller		ch	self-centrising transom					weight without rollers Kg
	ø mm	C		capacity Kg	H mm	K _{max}	Q	E	
800	133	958	18 - 22	158	150	367	1090	1150	32.9
1000		1158		209	150	375	1290	1350	38.6
1200		1408		167	150	375	1540	1600	43.1
1400		1608		227	150	389	1740	1800	50.5
1600		1808		202	150	389	1940	2000	54.6

800	159	958	18 - 22	158	150	387	1090	1150	34.2
1000		1158		209	150	395	1290	1350	39.9
1200		1408		167	150	395	1540	1600	44.4
1400		1608		227	150	409	1740	1800	52.0
1600		1808		202	150	409	1940	2000	55.9

Return roller and guide rollers type PSV/G7-NCD 20M16 60N 100 have to be ordered separately
Example of ordering
 Q1L, 800, F 14, 108
 Q1P, 1000, F 18, 133, YA