

FITTING THE PU-91 PRE-SCRAPER

1. Scraper segment PU 91
2. Beam
3. Holder H
4. PU-bushing
5. Hose clamp
6. Fixing plate for leverarm
7. Torsion leverarm and chain with snap hook and toothed washer
8. Leverarm fixing screw

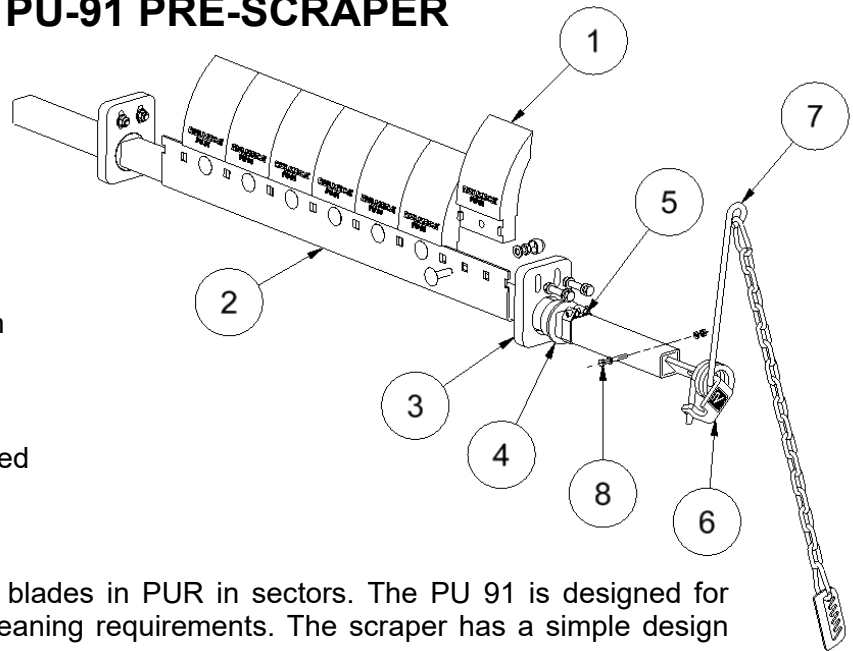

All steel parts are electro-galvanized

GENERAL INFORMATION

The PU 91 is a pre-scraper with blades in PUR in sectors. The PU 91 is designed for medium industry with stringent cleaning requirements. The scraper has a simple design with a minimum of moving parts.

IMPORTANT

In order to achieve the best scraping results, the following conditions must be met:

- The conveyor belt must be free of damage. The belt may otherwise catch on the scraper segments (1), resulting in a breakdown.
- Make sure that large pieces of material cannot bounce up and catch between the belt and the beam (2), causing damage to the belt and to the scraper.
- The scraper must not be fitted to chevron belts or belts with mechanical joints.
- Max. belt speed: **3.5** m/s. Can be used at speed up to 5 m/s with some modifications. Pls contact Rulmeca.
- Max. temperature: + 50 °C in wet environments.
- Max. temperature: + 85 °C in dry environments (ambient temperature + frictional heat).

CAUTION

Always turn off the belt conveyor before installing or carrying out maintenance on the scraper. Make sure that the belt cannot start while this work is in progress.

FITTING

1.	The scraper is placed against the drive pulley with the centre of the beam (2) at a radius (L) from the centre of the pulley. How high the scraper is placed on the pulley is determined by: a) the slope of the conveyor, b) the speed of the belt and c) the space available.
2.	PLEASE NOTE: The flow of material must not hit the segments (1).
3.	Slip the holders (3), the PU-bushes (4) and the hose clamps (5) onto the beam (2).
4.	Make two mounting plates (=flat bars with two holes Ø11 mm) and weld these to the frame. We suggest attaching them in the vicinity of the drive pulley bearings.
5.	Bolt the holders (3) to the mounting plates. Check that the L measurements are correct and that the PU blade (1) touches the belt (see picture).
6.	Centre the scraper on the pulley and lock the beam laterally using the hose clamps. Cut the beam to a suitable length.
7.	Mount the Torsion lever arm (7) onto the fixing plate (6). Make sure that the short spring pin locks in the notch on the fixing plate.
8.	Insert the fixing plate (6) into the end of the beam (2). Drill a hole (Ø7 mm) right through the square tube and lock the fixing plate (6) using an M6 x 50 mm bolt (8).
9.	Weld the toothed washer to the conveyor frame. Set the lever arm (7) and hook the snap hook onto the toothed washer. Find the optimal pressure by trial.

MAINTENANCE

Inspect and clean the scraper regularly – we suggest once a week. When half the blade height remains, change all the segments (1). Change the segments by undoing the M12 nuts. Bolt on the new segments. Set the scraper, lock the chain to the frame. Readjust the scraper pressure so as to achieve optimal cleaning. There must be no vibrations or noise. However, vibrations may arise when the belt is run without material or when the belt has a coating of resin. In the long term, vibrations may result in cracking of the beam. These must therefore be eliminated. Try therefore:

- changing the angle of the blades against the belt a few degrees
- changing the pressure of the blades against the belt
- making a more robust attachment to the frame
- increasing the mass of the beam (2) by, for example, fitting a small weight to the beam.

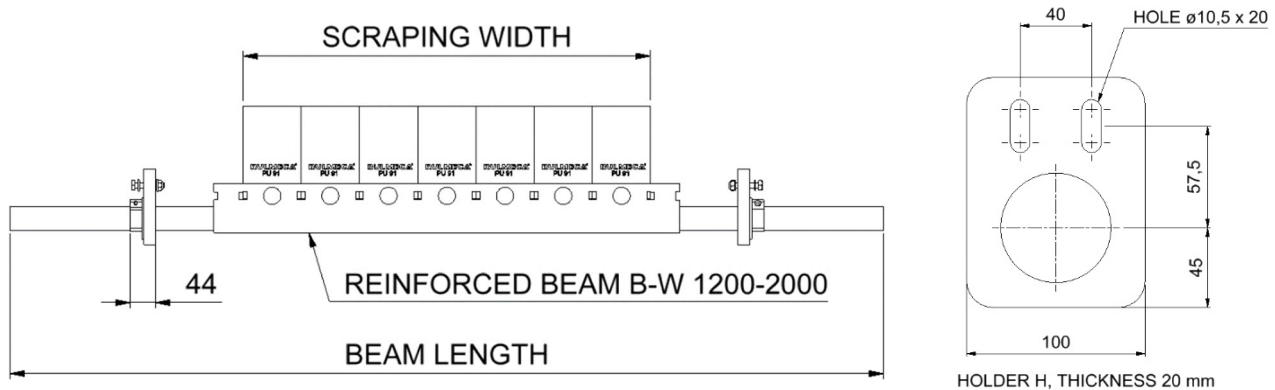

BW	SEGMENTS	SCRAPING WIDTH	BEAM LENGTH	NO OF LEVERARMS
400	4	400	1100	1
500	5	500	1200	1
650	6	600	1300	1
800	7	700	1500	1
1000	9	900	1700	2
1200	11	1100	1900	2
1400	13	1300	2000	2
1600	15	1500	2300	2
1800	17	1700	2500	2
2000	19	1900	2700	2

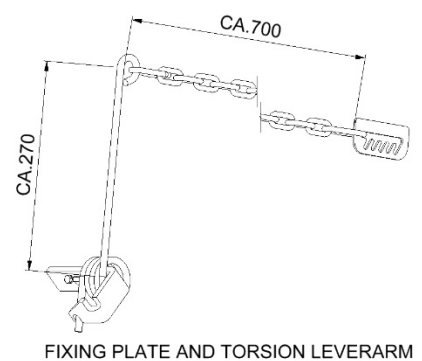

PULLEY	L-MESSURE
Ø220	227
Ø270	246
Ø320	262
Ø400	290
Ø500	330
Ø630	390

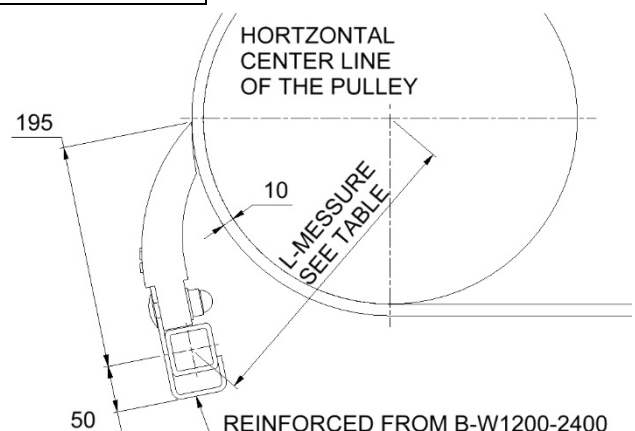

WARRANTY

Damage to the scraper caused by incorrect handling or in connection with incorrect installation cannot be considered to be covered by warranty if these instructions have not been followed. We therefore accept no claims for any consequential damage or loss.